



# CUBICLE CLEANING



EMILY - ZA Les Landes - 29800 Tréflévénez - France  
T. +33 (0)2 98 21 86 12 / F. +33 (0)2 98 21 86 14  
export@emily.fr

[www.emily.fr](http://www.emily.fr)



# AM READY

**1H** SAVE 1 HOUR EVERY DAY

## HOW IT WORKS

NEW

The AM ready is a self propelled bedding machine. It enables the cleaning, the scraping and the spreading of the cubicles.

**SWEEP**

**SCRAPE**

**SPREAD**



## EMILY ADVANTAGES

- Small 1.35m turning circle
- Crossing steps up to 20 cm (optional)
- Exceptional traction and maneuverability with 3-wheel drive and rear wheel steering
- Up to 12 kph working speed range
- Hydraulic steering



1.35M turning circle



Hydraulic steering



Power steering



Crossing steps



Scraping blade in V shape

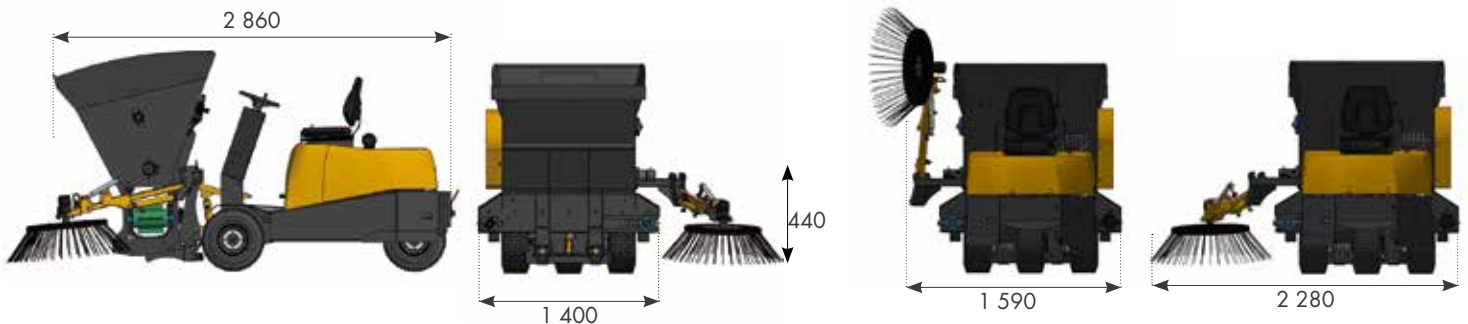

## SPECIFICATIONS

### MACHINERY HANDLER

- Diesel engine Kohler 17hp four stroke cycle, 2 cyl engine, hour meter and electric start, water cooled, axial ventilator
- Hydrostatic drive to all 3 wheels (dimensions 18/8.50-8) • Variable stroke hydraulic piston pump for infinite speed
- Flow gear pump to control all attachments (25L/min) • Manual electric brake • Power assisted orbital steering
- Rear wheel steering with up to 90° movement resulting in a tight 1.35m turning circle • Length: 1m

### MICRO'DIS

- Working volume : 0,88 m<sup>3</sup> (matter density : 0,3) • Water volume : 700 litres • PVC belt with guiding and sealing profile
- Right and left spreading • Bottom agitator with knives • Top agitator with blades
- Flared end structure with perforated rear extensions for visibility

### SIDE BRUSH

- Mono Left hand side brush Ø 900mm (the bedding belt is working independently from the brush)

### SPEED VARIATOR

- Manual flow speed variation for right discharge

# MINI'DIS WITH SIDE BRUSH

**1H** SAVE 1 HOUR EVERY DAY

## HOW IT WORKS

This compact bedding bucket fits onto front loader of tractors, 3rd point of tractors, skids and compact loaders. This bucket is a versatile attachment : you can clean cubicles with the side brush (optional) and then bed with sawdust, shavings, chopped straw, lime (...) and also feed silage.



**100%  
GUARANTEE  
CLEAN  
UDDERS**

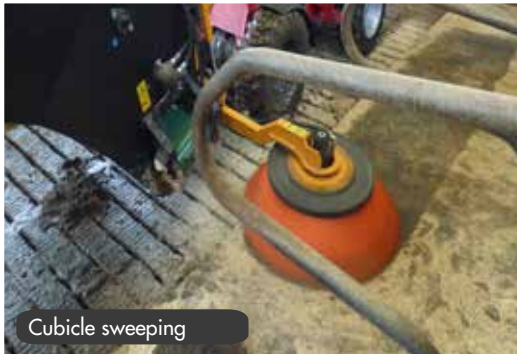
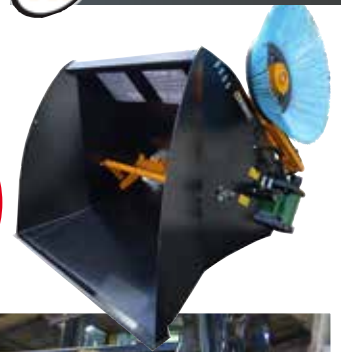

Cubicle sweeping



Spreading



Feeding

## EMILY ADVANTAGES

- A 3 in 1 product ! It sweeps, spreads and feeds on front or rear of the machinery handler.
- User friendly.
- The Mini'Dis bedding bucket with the integrated brush is ideal for narrow buildings with its flared end structure enabling the user to load and brush along the walls.
- As it is a compact bucket with a top perforated metal sheet it ensures a good visibility.
- Easy cleaning of uneven floor and corners.
- Time saving: no more heavy manual work. Cost savings for materials : optimal dosing of bedding material.
- Fast working and low maintenance.

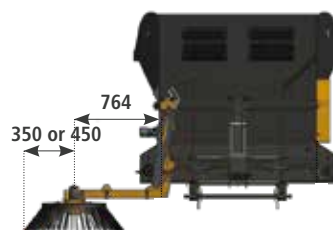
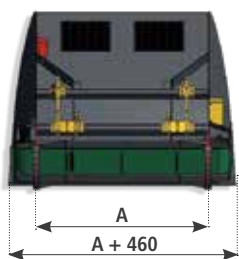

**Retractable side brush  
integrated axles  
Half-integrated motor**

## SPECIFICATIONS



Width (m) (A)	1,00	1,20	1,40
Water volume (L)	1 000	1 300	1 500
Using capacity (m <sup>3</sup> )	1,25	1,60	1,90
Weight without options (kg) MINI'DIS	310	365	430
Weight without options (kg) MINI'DIS+	N/A	475	530



## STANDARD EQUIPMENT

- PVC belt (245mm width) with guiding sealing profile
- Right and left discharge
- Direct drive of the bottom agitator with knives (simultaneously with the belt)
- Drive of the chain of the top agitator (gear / chain)
- Flared end structure
- Top perforated metal sheet.

## ADAPTATION

**MINI'DIS**  
• Adjustable, removable and bolted adaptation for loader <70HP (Type 1: square tubes 60x60).

**MINI'DIS +**  
• Adjustable, removable and bolted adaptation for loader >70HP and rear linkage (Type 2: square tubes 80x80)

# MINI'DIS T BEDDING BUCKET



Cubicle sweeping

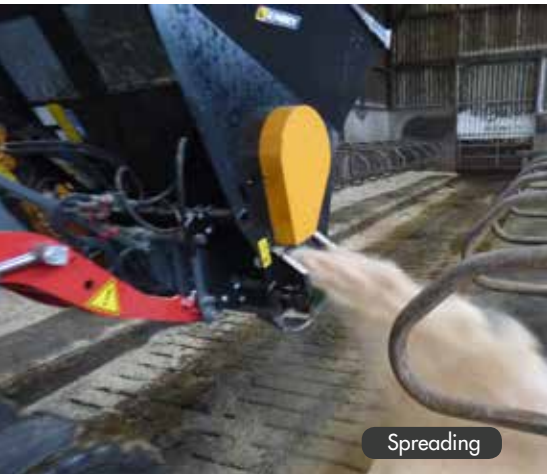

Spreading



Feeding



## NEW

The Mini'Dis T Bedding Bucket is available for front loader and telescopic loader (>2,2T and <3,5T).

This bucket is designed to spread sawdust, wood chips and chopped straw <10cm and occasionally maize silage.

## STANDARD EQUIPMENT : REFER TO MINI'DIS AND MINI'DIS+ BEDDING BUCKETS

Overall width (m)	2,26
Water volume (L)	2 000
Using capacity (m <sup>3</sup> )	2,50
Weight with no options (kg)	820

## OPTIONS

- ➔ EXTENSION 3M3
- ➔ SIDE BRUSH 700 OR 900
- ➔ SPEED VARIATOR



Removable adaptation



Drums' adjustment

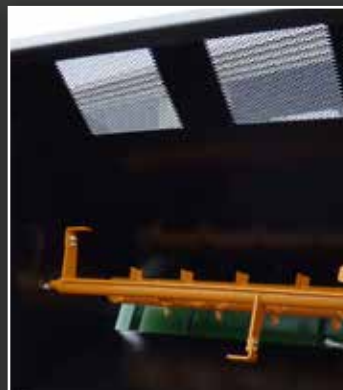

Perforated metal sheet and bolted folded sections on the top agitator

## OPTIONS

- ➔ REMOVABLE DISCHARGING FLOW LIMITER FOR LIGHT PRODUCTS
- ➔ SIDE BRUSH 700 OR 900
- ➔ ELECTRIC SELECTOR BOX
- ➔ HYDRAULIC CHASSIS FOR REAR LINKAGE

**FOR MORE OPTIONS, PLEASE CONTACT US.**

# MULTI'DIS



EXCEPTIONAL EFFICIENCY

## HOW IT WORKS

The Multi'dis Bedding Bucket fits onto front loaders, linkage of tractors and telescopic handlers. The Bedding Bucket is especially designed to enable farmers to bed easily lying boxes, poultry houses minimizing dust. The Bedding Bucket is designed to spread sawdust, wood shavings, chopped straw, compost, bark and to distribute maize silage (optional). Patented and unique on the market: the hydraulically driven agitating system (High Speed Discharge System) prevents from bridging.



**MATERIAL:** sawdust, wood shavings, chopped straw and maize silage (option)

## EMILY ADVANTAGES

- Excellent visibility from the cab: compact bucket.
- Optimized loading thanks to the bucket shape.
- Uniform layer of bedding material.
- Material and time saving: it regulates the material quantity to be spread and facilitates a daily job.
- Fast operation, maintenance free.

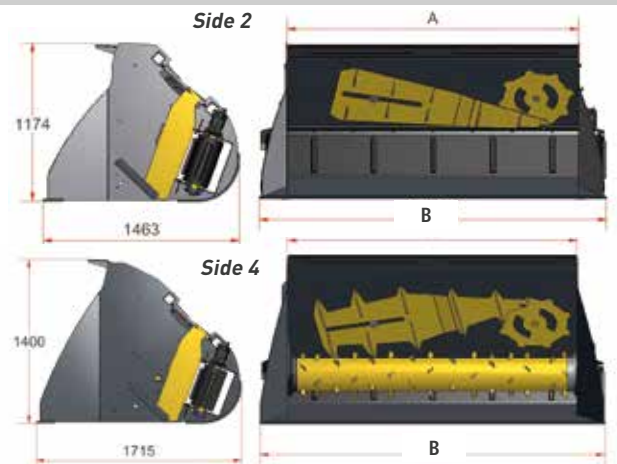
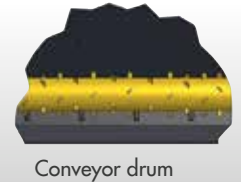

## SPECIFICATIONS



Inside width (A)	1,60	1,80	2,00	2,20				
Working volume (m <sup>3</sup> )	1,40	2,10	1,50	2,30	1,70	2,60	1,90	2,90
Overall width (m) (B)	2,00	2,20	2,40	2,60				
Empty weight with no options (kg)	590	600	660	700	730	800	800	900

## STANDARD EQUIPMENT

- Bucket with flared end
- Agitating system to prevent from bridging (Patented) and synchronized with the distribution
- Continuous belt with no staples
- Curved and vulcanized motor roll
- Bulged and vulcanized rear roller
- Perforated rear extensions
- Side guide belts for the belt
- Right and left discharge with mechanical adjustment of the doors
- Bolted adaptation

## OPTIONS

- Rotor necessary for chopped straw spreading
- Rotor synchronized with the belt for difficult products
- Hydraulic grab 2 rams
- Load limiter for the distribution belt (for maize/ compost)
- Anti-projection flap for maize silage distribution to the front left / rear right hand side
- Extra welded blade
- Hydraulic opening of both doors

# «SPECIAL SAND» MULTI'DIS



EXCEPTIONAL EFFICIENCY

## HOW IT WORKS

The «Special Sand» Multi'dis fits onto front loaders, linkage of tractors and telescopic handlers. It is designed to spread sand. Patented and unique on the market: the hydraulically driven agitating system (High Speed Discharge System) prevents from bridging.



## EMILY ADVANTAGES

- Excellent visibility from the cab: compact bucket.
- Optimized loading thanks to the bucket shape.
- Material and time saving: it regulates the material quantity to be spread and facilitates a daily job.
- Fast operation, maintenance free.

SAND

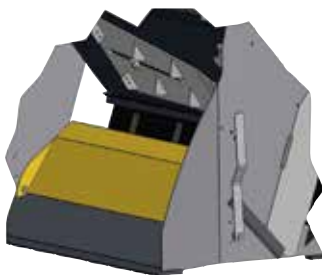

Load limiter



Hydraulic agitator system to prevent bridging

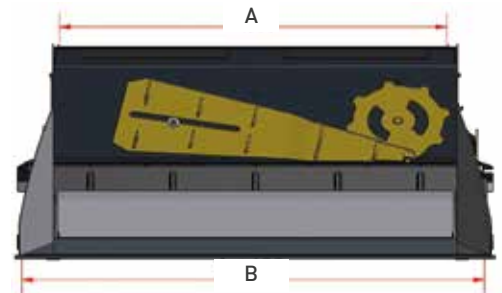

## SPECIFICATIONS

Inside width (m) (A)	1,25	1,60	1,80	2,00	2,20
Working volume (m <sup>3</sup> )	0,67	1,40	1,50	1,70	1,90
Overall width (m) (B)	1,55	2	2,20	2,40	2,60
Empty weight (kg)	395	640	710	780	850

## STANDARD EQUIPMENT

- Agitating system to prevent from bridging (Patented) and synchronized with the distribution
- Load limiter
- Discharging belt with reinforced rubber strip driven by a hydraulic motor
- Continuous belt with no staples
- Curved and vulcanized motor roll
- Side guide belts for the belt
- Right and left discharge with mechanical adjustment of the doors
- Powerful motor
- Bolted adaptation

## SPECIAL EQUIPMENT

0.67m<sup>3</sup> Model

- Adjustable, removable and bolted adaptation Category 1 for compact machinery and skid steer

1.40m<sup>3</sup> to 1.90m<sup>3</sup> Models

- Adjustable, removable and bolted adaptation Category 2 for agricultural machinery handlers

EMILY - ZA Les Landes - 29800 Tréflévénéz - France  
T. +33 (0)2 98 21 86 12 / F. +33 (0)2 98 21 86 14 / export@emily.fr

www.emily.fr

